

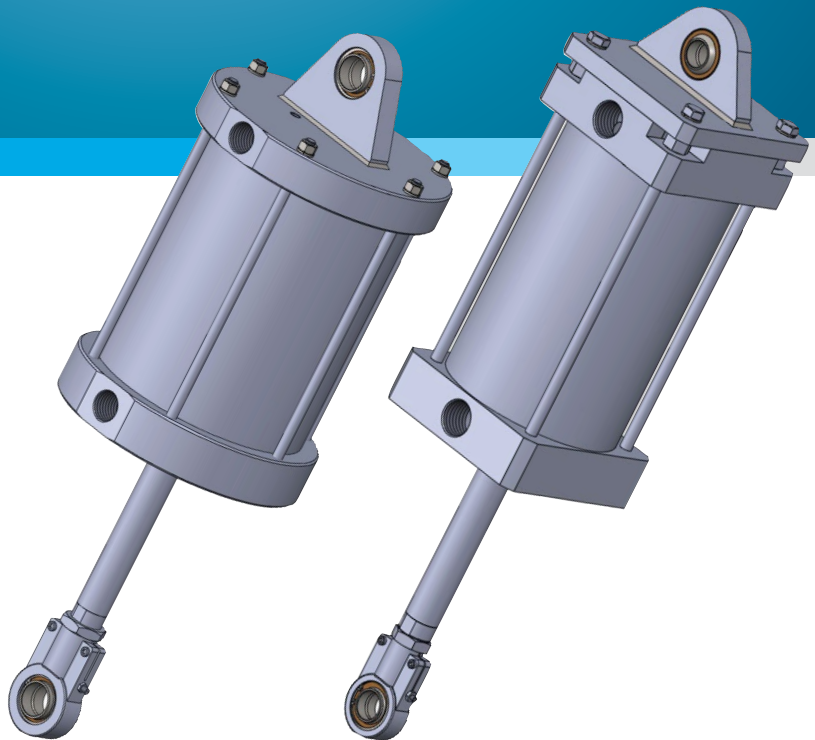

# NEW PRODUCT PATENTED DGL SERIES BALANCING CYLINDERS

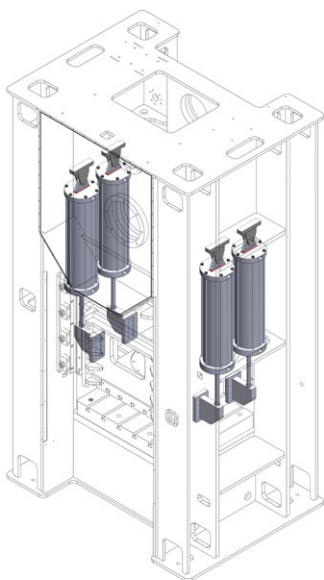

ONE BRAND, COMPLETE SOLUTIONS  
IN PNEUMATIC AUTOMATION



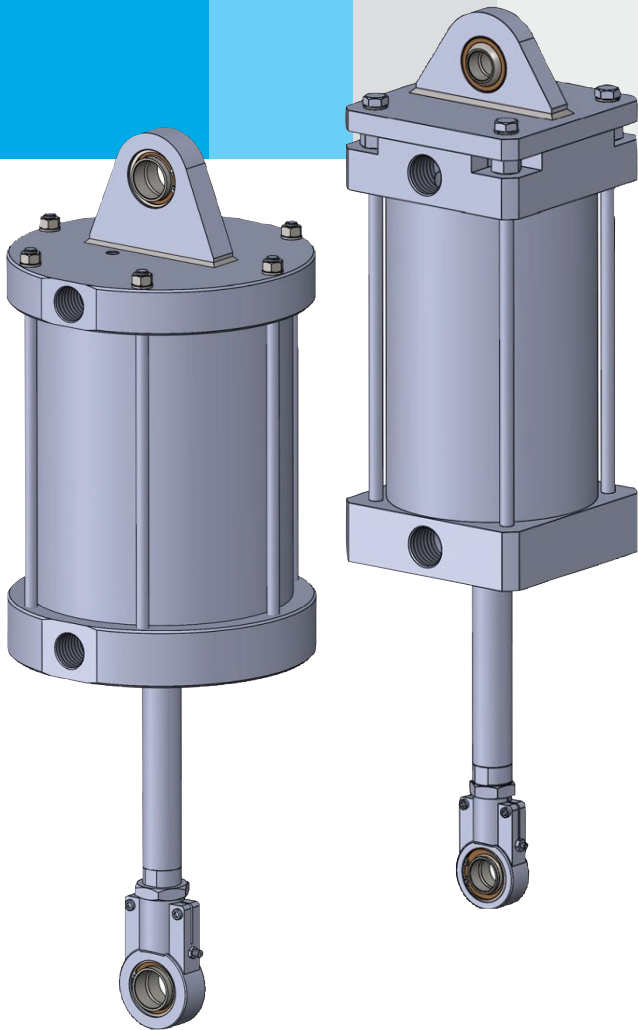

## DGL SERIES

### BALANCING CYLINDERS // Ø80-Ø400

#### SINGLE ACTING, PULL TYPE CYLINDER

- PATENTED SPECIAL PNEUMATIC CYLINDER DESIGNED TO BALANCE RAM WEIGHT OF PRESSES
- Ø80-Ø100-Ø125-Ø160-Ø200-Ø250-Ø320-Ø400 mm 8 DIFFERENT DIAMETER ALTERNATIVES
- SPECIAL CHROME PLATED AND HARDENED ROD TO MINIMIZE WEARING
- GREASE MINIMIZING FRICTION DURING MASS PRODUCTION
- SPECIAL DESIGN PISTON AND ROD SEALS
- ADDITIONAL AIR OUTLET HOLES FOR QUICK EXHAUST AND REDUCING HEAT DURING OPERATION
- CAPS ARE SQUARE BETWEEN DIAMETERS 80-200 AND BODY-CAP ASSEMBLY IS DONE BY 4 TIE RODS
- CAPS ARE CIRCULAR FOR DIAMETERS 250-320-400 AND BODY-CAP ASSEMBLY IS DONE BY 6 TIE RODS
- SINGLE ACTING AND WORKING ON PULL SIDE
- SUGGESTED AIR PRESSURE IS 10 BAR, MAXIMUM AIR PRESSURE IS 16 BAR FOR INSTANT LOADS

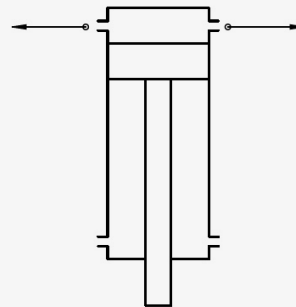

**DGL**  
SINGLE ACTING,  
PULL TYPE CYLINDERS

### OPERATING CONDITIONS

**Operating fluid:**

Filtered and oiled air or filtered air without oil

**Operating temperature:**

Polyurethane (PU): (-30°C) - (+80°C)

**Maximum operating pressure:**

10-16 Bar

\*Please contact us for cylinder diameters over 400 mm.

### FORCE

Cylinder Ø mm	Rod Ø mm	TRACTION FORCE (N)	
		6 Bar	10 Bar
80	25	2720	4530
100	25	4420	7360
125	32	6880	11460
160	32	11580	19290
200	40	18090	30140
250	40	28680	47810
320	50	47050	78420
400	63	73490	122480

### ORDER SAMPLE

DGL                      320-500                      KEB - KMB-K  
Series                      Cylinder Ø Stroke                      Cylinder Mountings

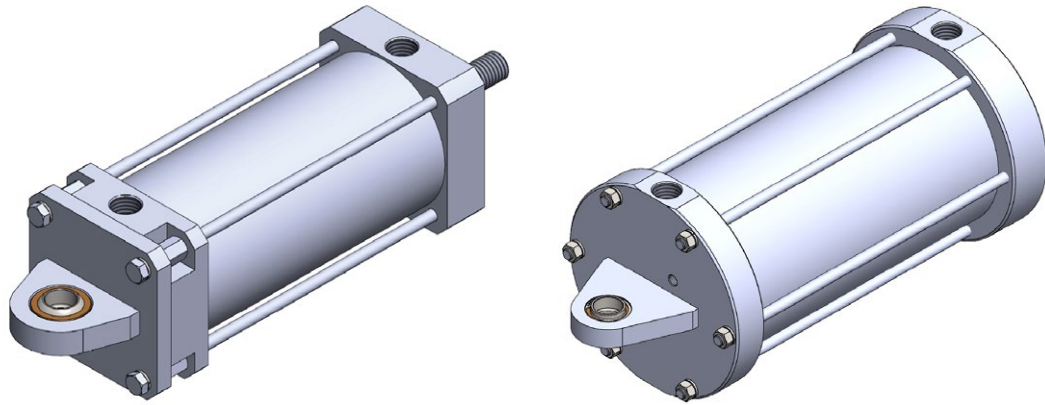

**SPECIAL DESIGN PISTON AND ROD SEALS.**

**PISTON SEAL**

- Specially designed rod seal can work under high pressure and it enables higher speed as a result of low friction
- Strong body structure provides long life against tearing and wearing out

**ROD SEAL**

- Specially designed body structure provides superior leak-tightness by resistance against tearing and wearing out
- Scraper feature enables a perfect operation even under heavy conditions (dust, dirt etc.) And protects cylinder from particles

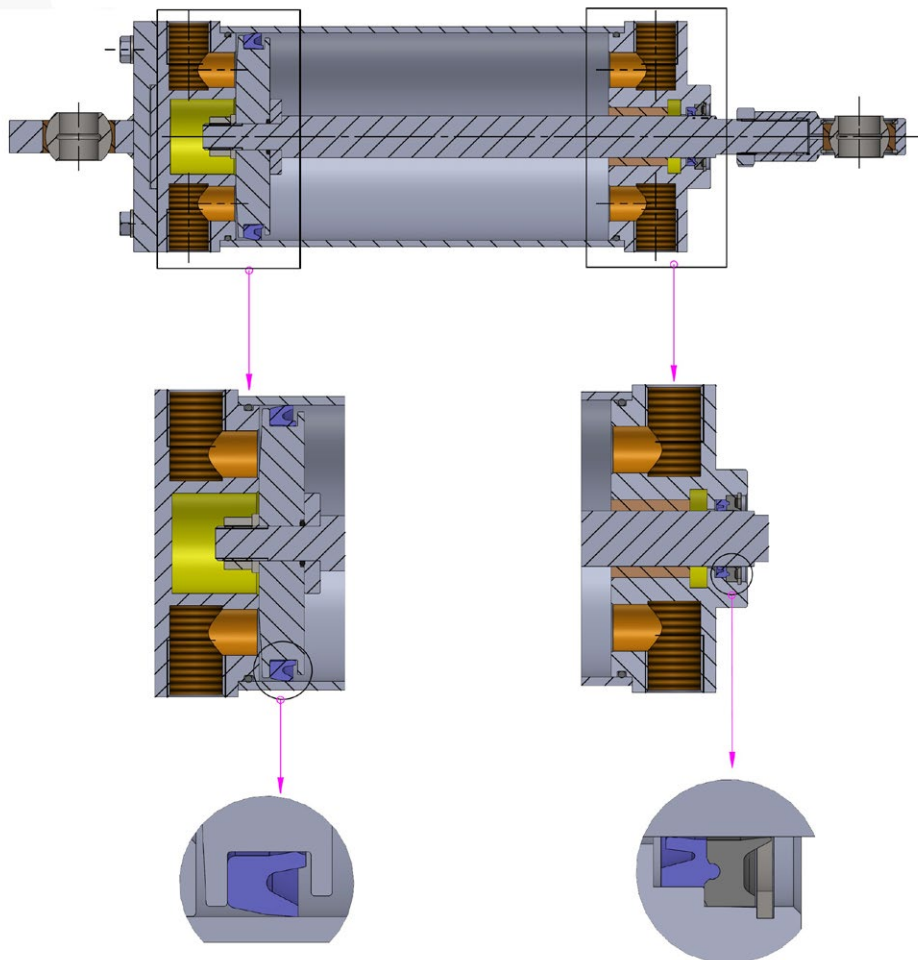

**ADDITIONAL GUIDING RODS POSITIONED INSIDE THE CYLINDER PROVIDES PERFECT LINEAR OPERATION.**

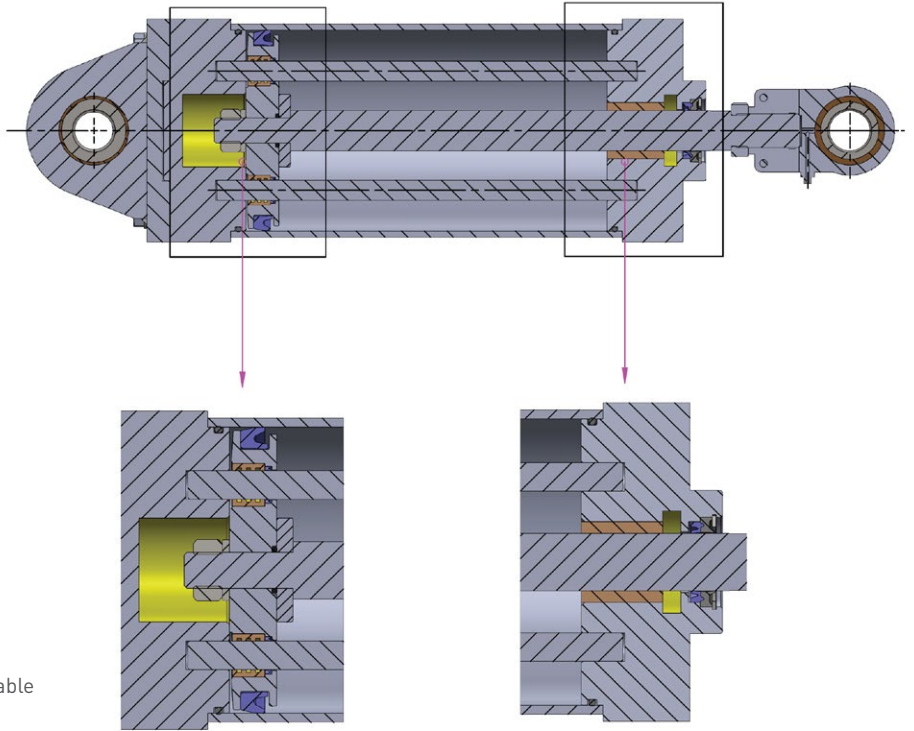

Note: Additional guiding rods are available for cylinder diameters 125 and above.

**SPHERICAL MOUNTINGS ON ROD SIDE AND REAR CAP ARE AVAILABLE FOR MINIMIZING AXIAL LOADS AND DEFLECTIONS.**

**SPHERICAL MOUNTINGS**

- Enabling cylinder to operate without deflections by minimizing deviation between axis.

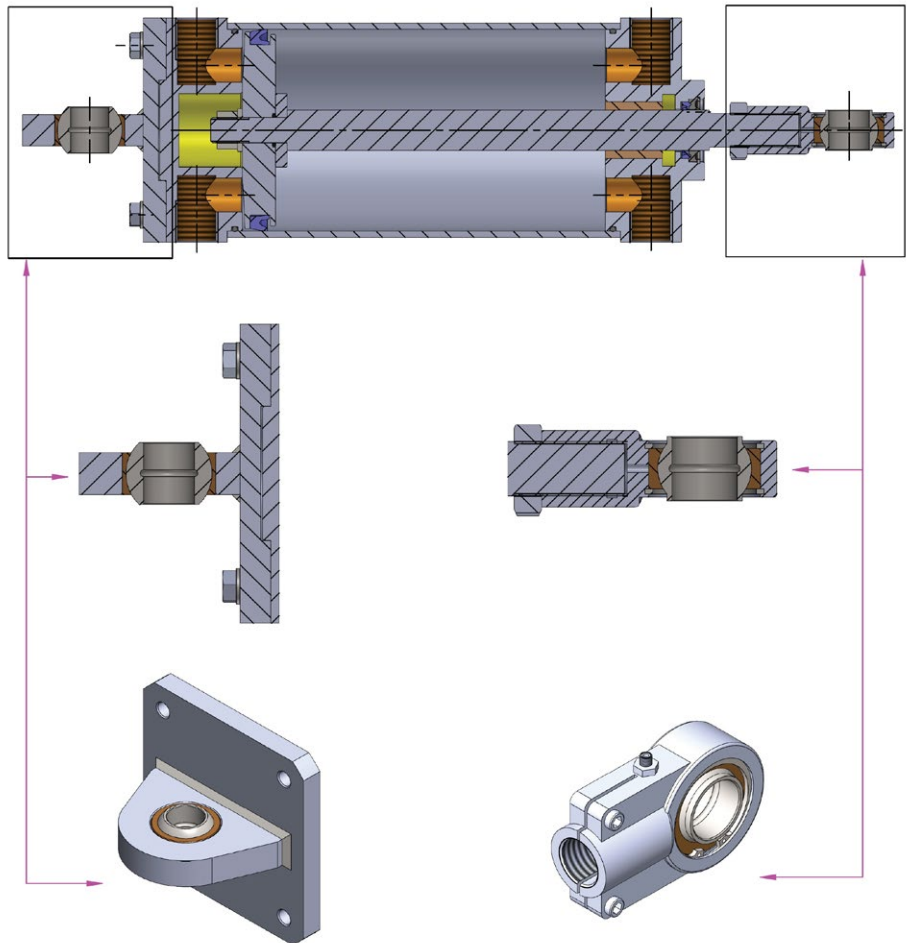



**THERE ARE CIRCULAR GREASE POOLS FOR ROD AND PISTON SEALS IN CYLINDERS. HOLES ARE AVAILABLE FOR APPLYING CENTRAL LUBRICATION.**

**GREASE POOLS**

- Interior centres of front and rear caps are designed for grease pools. So, manual and automatic grease addition is possible during whole operation life.
- Lubrication reduces friction inside the cylinder and prevents heat due to friction.

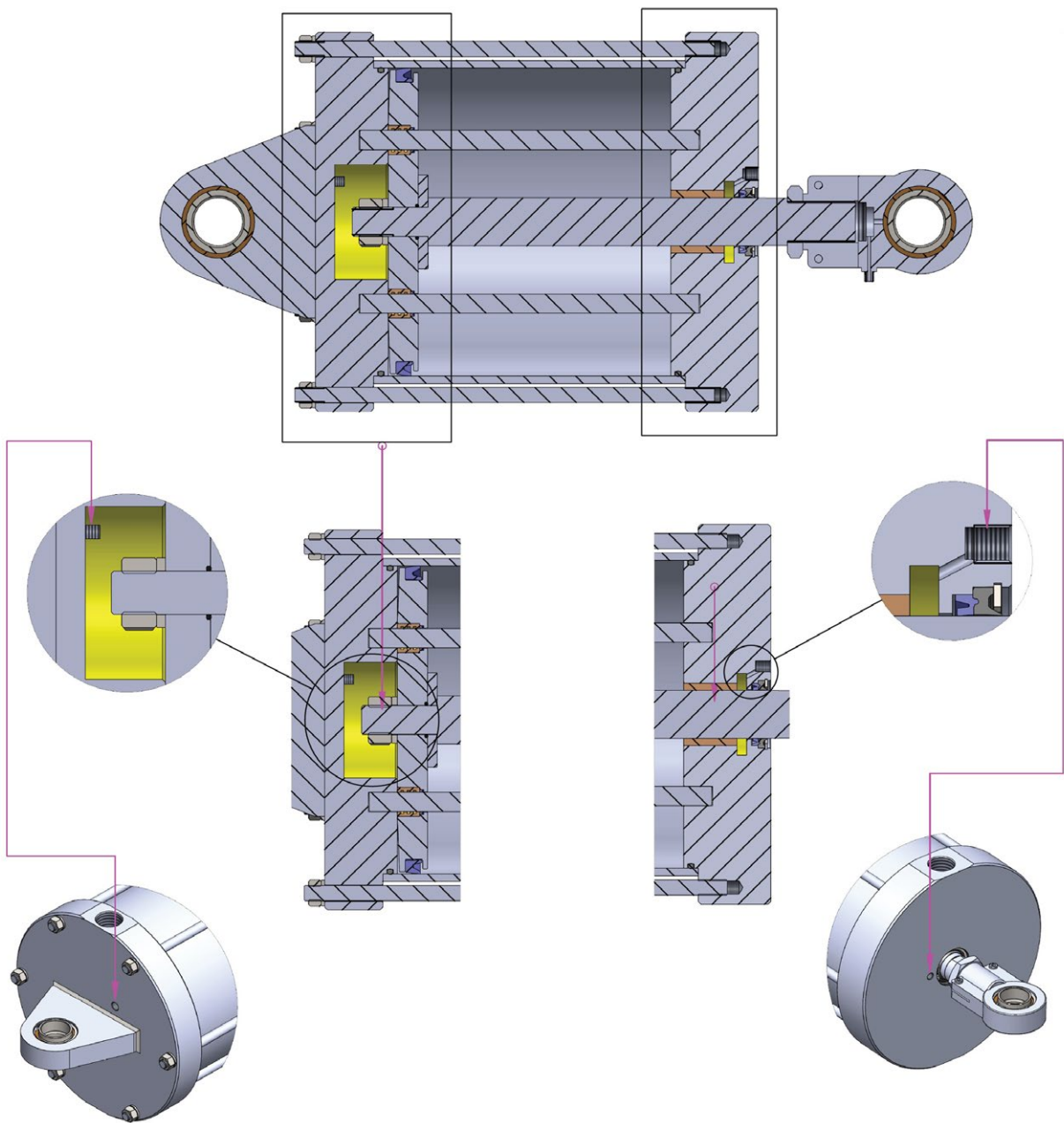

**ADDITIONAL AIR OUTLET HOLES ARE AVAILABLE FOR QUICK EXHAUST AND REDUCING HEAT DURING MASS PRODUCTION.**

#### **EXTRA INLET-OUTLET (PARALLEL AIR PORTS)**

- Cylinder reaches high working speed by the help of extra air holes and pressured air inside the cylinder is exhausted quickly via opposite air outlets. So, the heat inside the cylinder is reduced to optimum level.

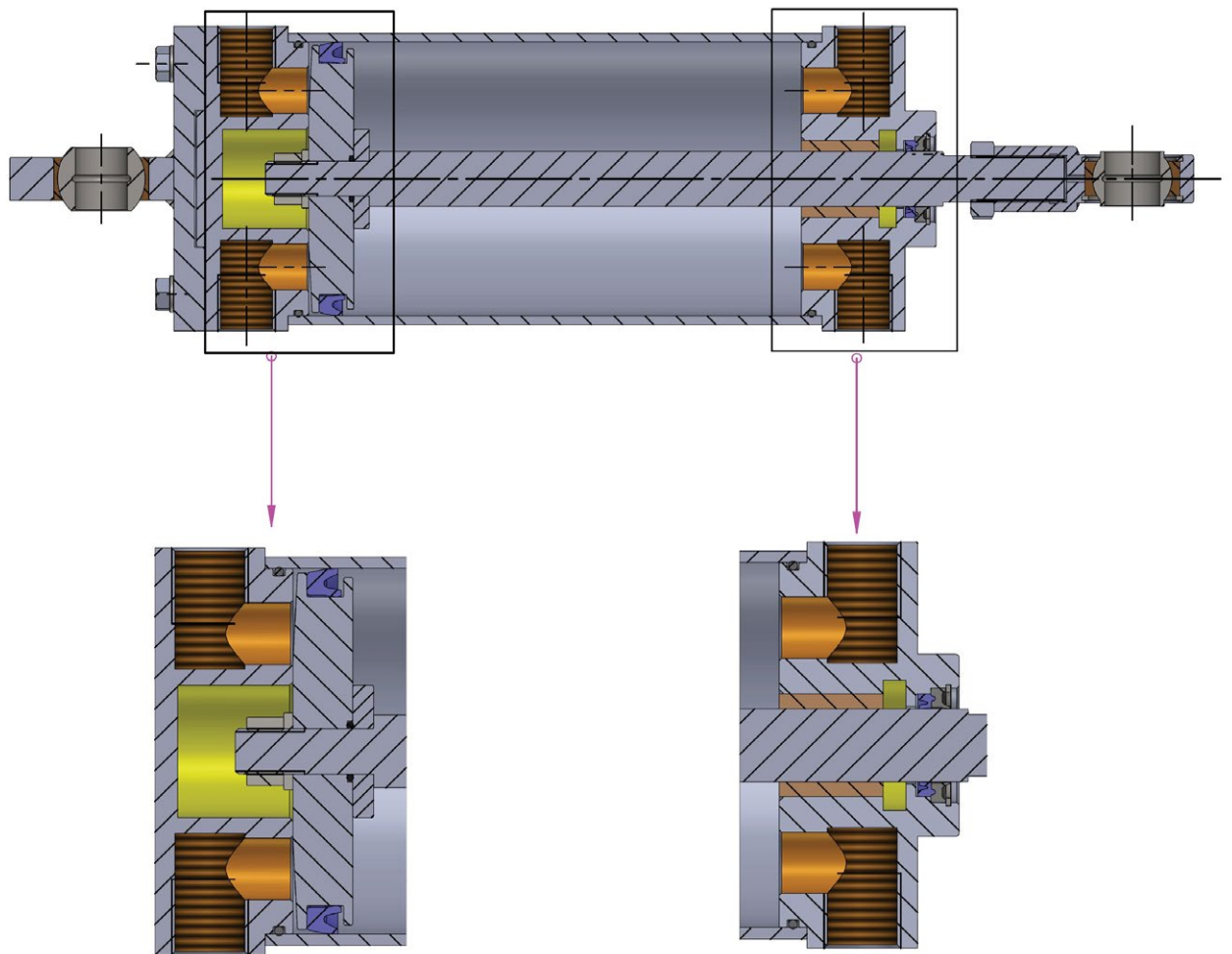

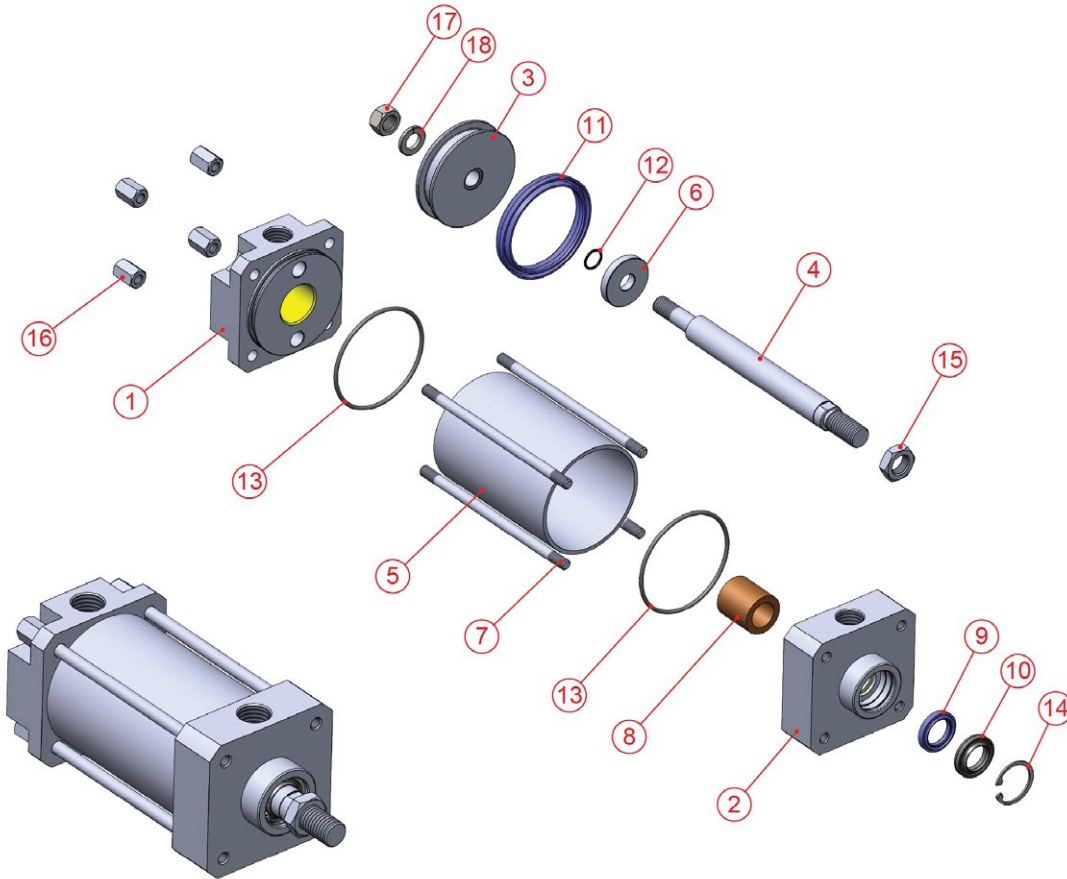
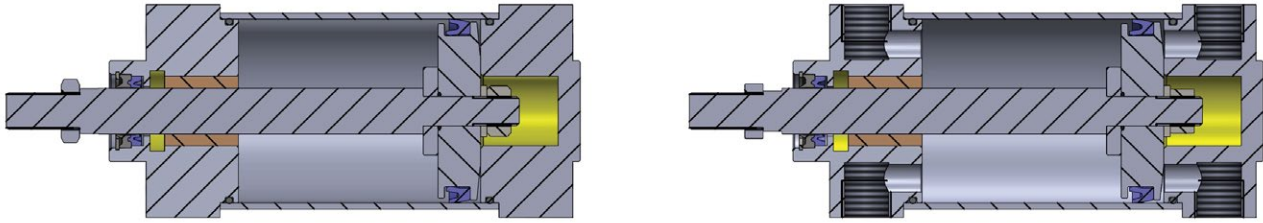

No	Material Name	Characteristic	Pc.
1	REAR CAP	STEEL	1
2	FRONT CAP	STEEL	1
3	MIDDLE PISTON	6082 AL.	1
4	PISTON ROD	CK45 HARD CHROME PLATED	1
5	TUBE	AlMgSi 0.5+ELOXAL PLATED	1
6	THRUST WASHER	GALVANIZED STEEL	1
7	TIE ROD	GALVANIZED STEEL	4
8	GUIDING BUSH	BRONZE	1
9	ROD SEAL	PU 85	1
10	SCRAPER SEAL	POM	1
11	PISTON SEAL	PU	1
12	MIDDLE PISTON O-RING	NBR	1
13	CAP O-RING	NBR	2
14	RETAINING RING	STEEL	1
15	ROD END NUT	GALVANIZED STEEL	1
16	NUT	GALVANIZED STEEL	4
17	MIDDLE PISTON NUT	GALVANIZED STEEL	1
18	SPRING WASHER	GALVANIZED STEEL	1



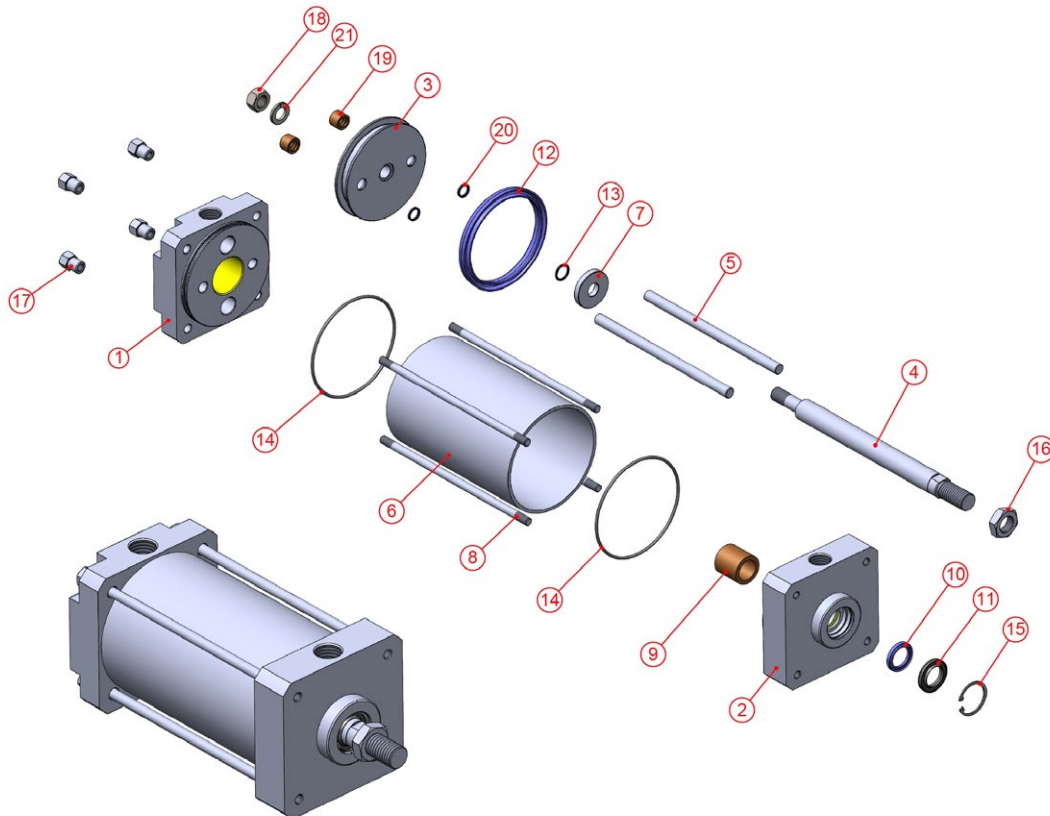
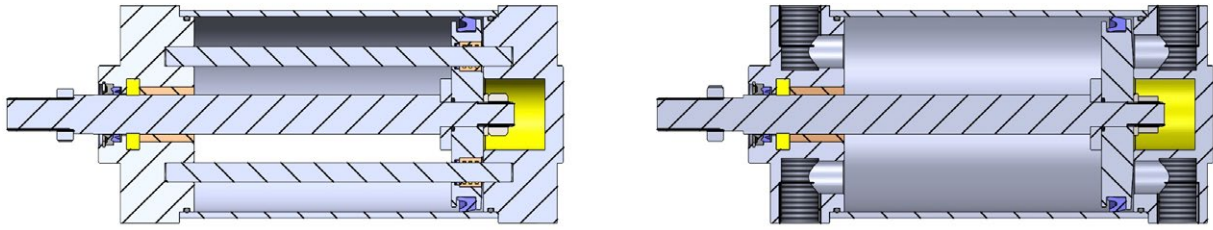

No	Material Name	Characteristic	Pc.
1	REAR CAP	STEEL	1
2	FRONT CAP	STEEL	1
3	MIDDLE PISTON	6082 AL.	1
4	PISTON ROD	CK45+HARD CHROME PLATED	1
5	NON-ROTATING GUIDE ROD	CK45+HARD CHROME PLATED	2
6	TUBE	AlMgSi 0.5+ELOXAL PLATED	1
7	THRUST WASHER	GALVANIZED STEEL	1
8	TIE ROD	GALVANIZED STEEL	4
9	GUIDING BUSH	BRONZE	1
10	ROD SEAL	PU 85	1
11	SCRAPER SEAL	POM	1
12	PISTON SEAL	PU	1
13	MIDDLE PISTON O-RING	NBR	1
14	CAP O-RING	NBR	2
15	RETAINING RING	STEEL	1
16	ROD NUT	GALVANIZED STEEL	1
17	T-NUT	GALVANIZED STEEL	4
18	MIDDLE PISTON NUT	GALVANIZED STEEL	1
19	GUIDING BUSH	BRONZE	2
20	GUIDE ROD SEAL	PU	2
21	SPRING WASHER	GALVANIZED STEEL	1

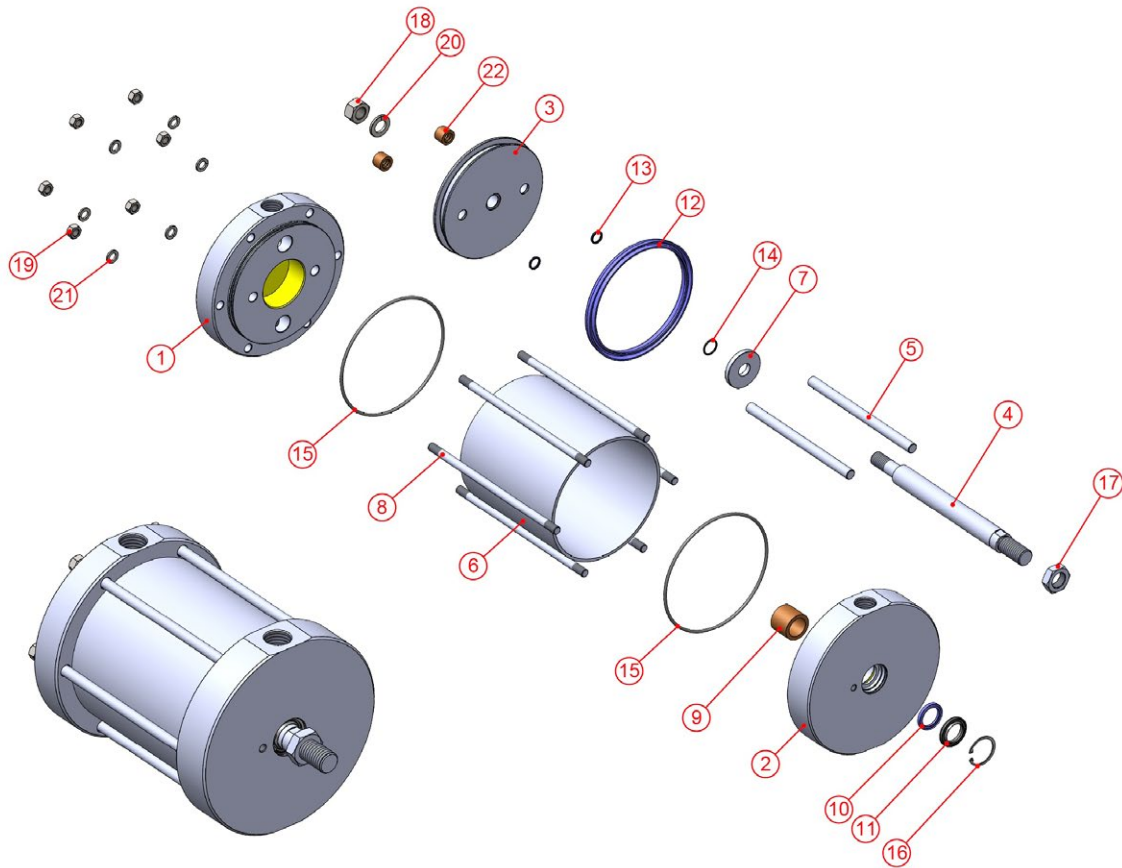
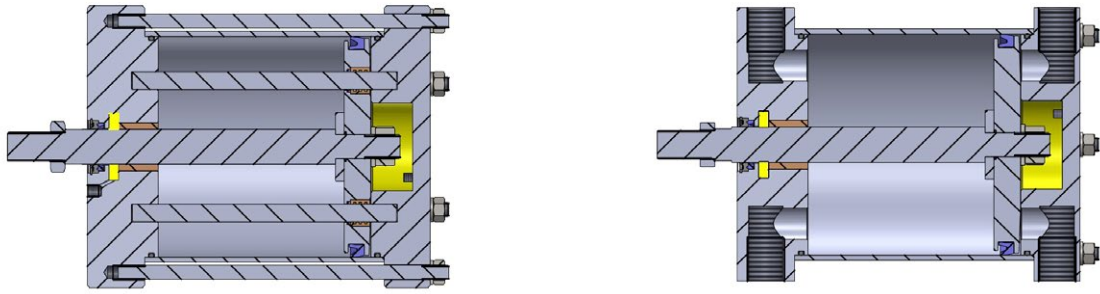

No	Material Name	Characteristic	Pc.
1	REAR CAP	STEEL	1
2	FRONT CAP	STEEL	1
3	MIDDLE PISTON	6082 AL.	1
4	PISTON ROD	CK45+HARD CHROME PLATED	1
5	NON-ROTATING GUIDE ROD	CK45+HARD CHROME PLATED	2
6	TUBE	STEEL	1
7	THRUST WASHER	GALVANIZED STEEL	1
8	TIE ROD	GALVANIZED STEEL	6
9	GUIDING BUSH	BRONZE	1
10	ROD SEAL	PU 85	1
11	SCRAPER SEAL	POM	1
12	PISTON SEAL	PU	1
13	GUIDE ROD SEAL	PU	2
14	MIDDLE PISTON O-RING	NBR	1
15	CAP O-RING	NBR	2
16	RETAINING RING	STEEL	1
17	ROD NUT	GALVANIZED STEEL	1
18	MIDDLE PISTON NUT	GALVANIZED STEEL	1
19	NUT	GALVANIZED STEEL	6
20	SPRING WASHER	GALVANIZED STEEL	1
21	SPRING WASHER	GALVANIZED STEEL	6
22	GUIDING BUSH	BRONZE	2

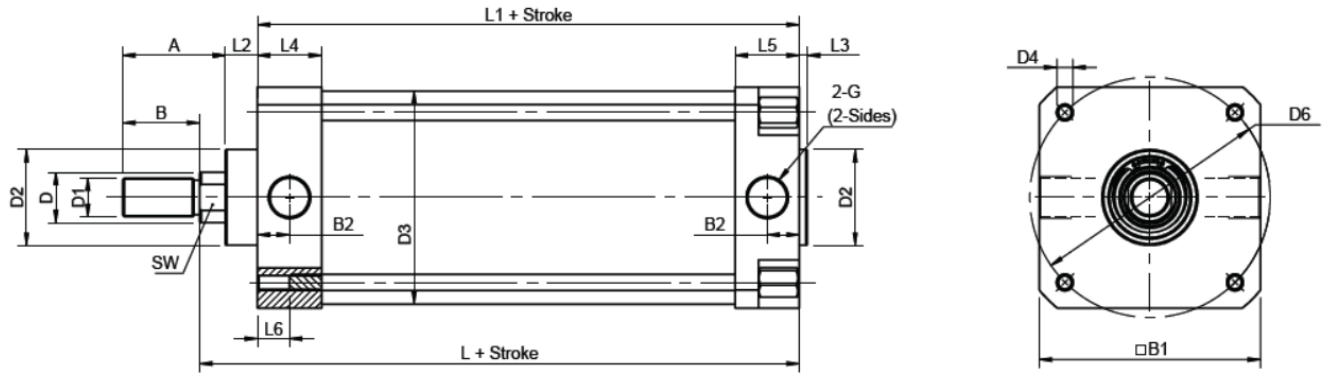

Cylinder Ø mm	A	B	B1	B2	D Ø	D1	D2 Ø	D3 Ø	D4	D6 Ø	L	L1	L2	L3	L4	L5	L6	SW	G
80	56	40	96	20	25	M20x1.5	55	86	M10	100	166	130	20	4	40	40	20	22	G3/4"
100	56	40	116	20	25	M20x1.5	55	107	M10	120	167	131	20	4	40	40	20	22	G3/4"
125	64	48	138	20	32	M24x2	60	133	M10	150	174	138	20	5	40	40	20	27	G3/4"
160	74	54	178	24	32	M27x2	80	170	M12	190	193	155	18	5	48	48	24	27	G1"
200	74	54	217	30	40	M27x2	80	210	M14	232	219	181	18	5	60	60	30	36	G1-1/4"

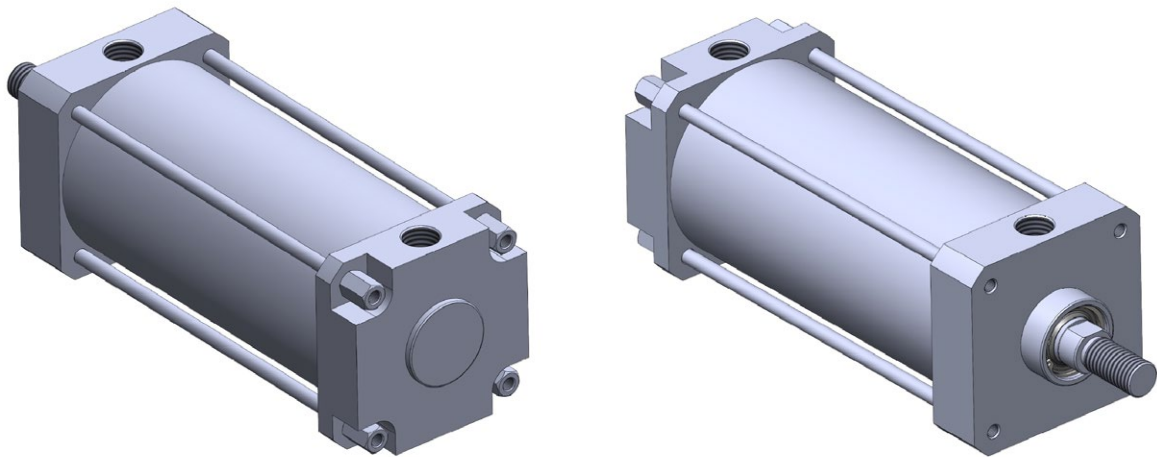

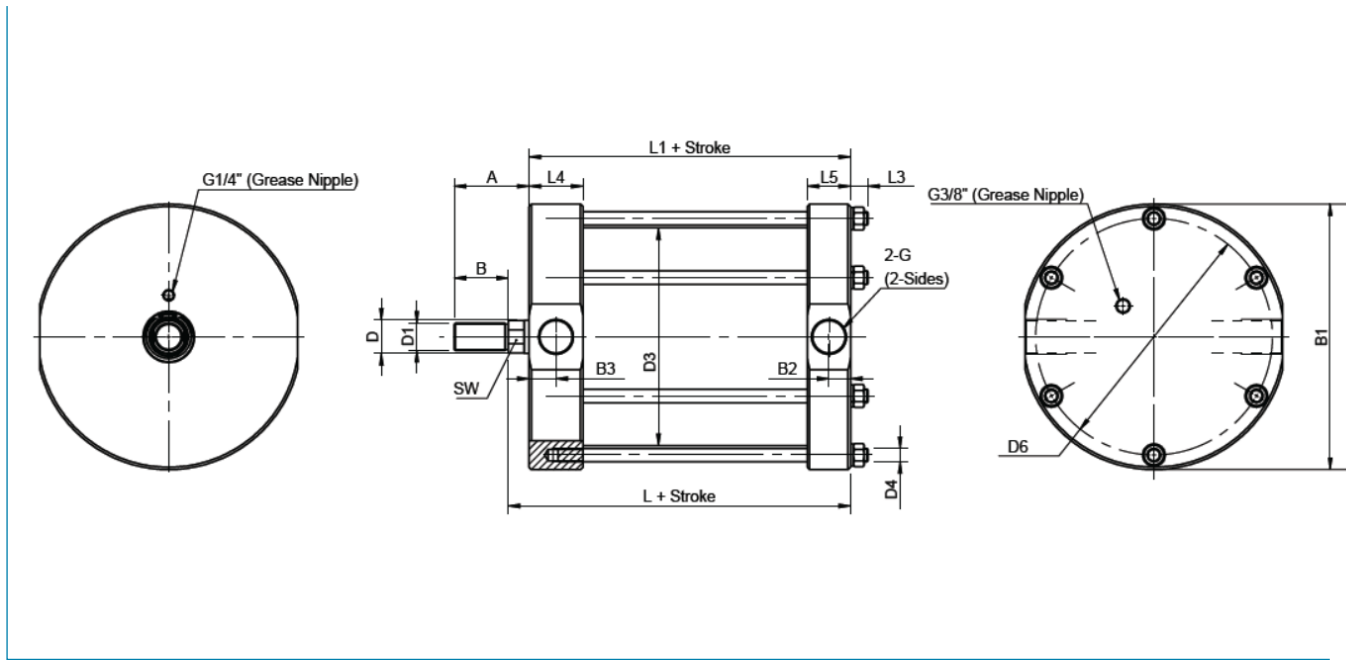

Cylinder Ø mm	A	B	B1 Ø	B2	B3	D Ø	D1	D3 Ø	D4	D6 Ø	L	L1	L3	L4	L5	SW	G
250	90	65	320	26	32.5	40	M33x2	262	M16	285	212	187	21	65	52	36	G1-1/4"
320	100	70	395	30	37.5	50	M42x2	336	M16	360	236	206	21	75	60	46	G1-1/2"
400	115	80	485	30	37.5	63	M48x2	419	M20	445	252	217	26	75	60	55	G1-1/2"

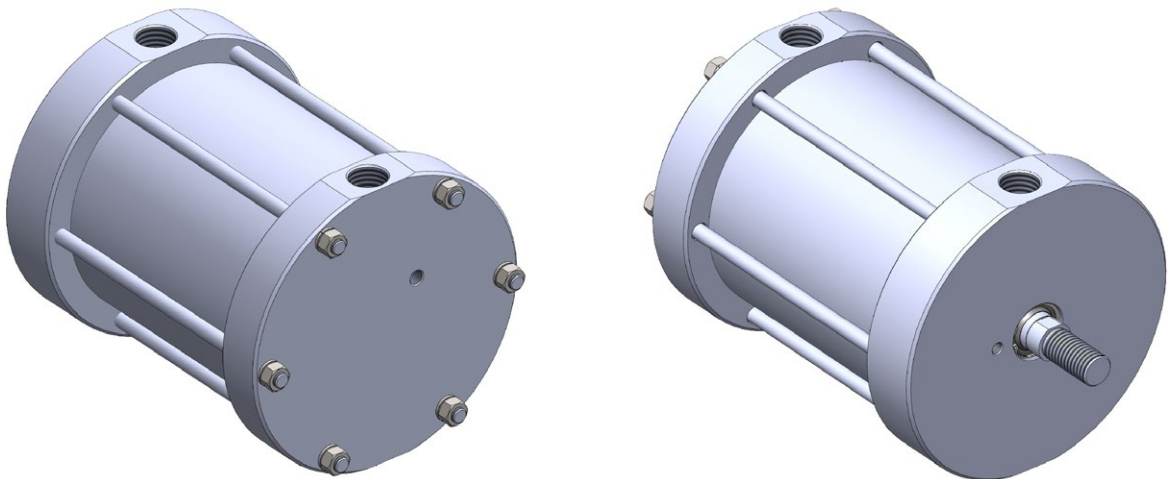

\*Please contact us for cylinder diameters over 400 mm.

**KEB (SPHERICAL SWIVEL FLANGE) Ø80, Ø100, Ø125, Ø160, Ø200**

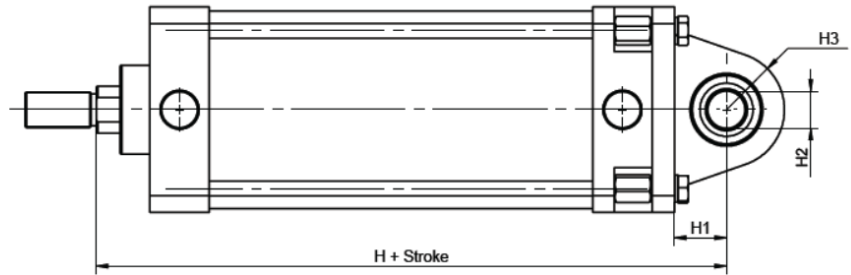
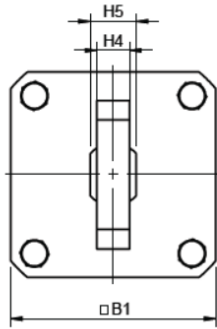

**KEB (SPHERICAL SWIVEL FLANGE) Ø250, Ø320, Ø400**

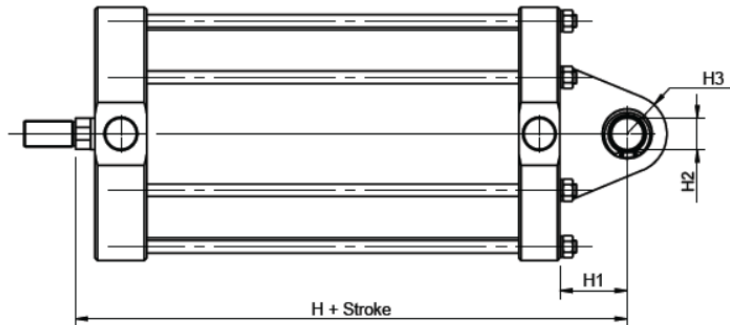
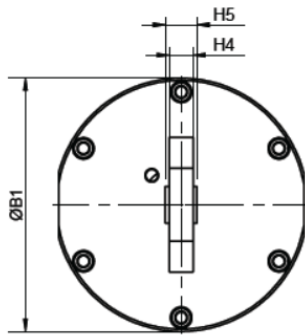

Cylinder Ø mm	Part Number	B1	H	H1	H2 Ø	H3	H4	H5
80	KEB-8020	96	208	28	20	34	18	25
100	KEB-10020	116	209	28	20	34	18	25
125	KEB-12525	138	224	35	25	39	22	31
160	KEB-16030	178	253	42	30	53	25	37
200	KEB-20030	217	283	42	30	53	25	37
250	KEB-25040	320	297	85	40	50	30	40
320	KEB-32050	395	336	100	50	60	40	50
400	KEB-40063	485	367	115	63	70	50	63

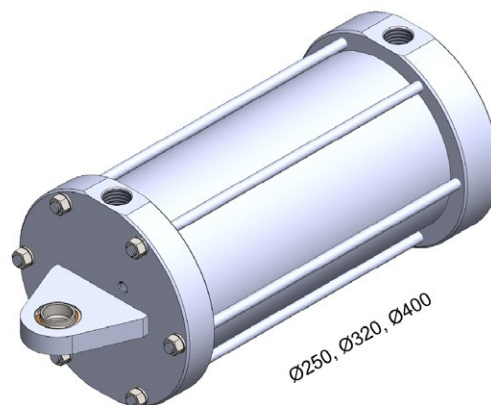
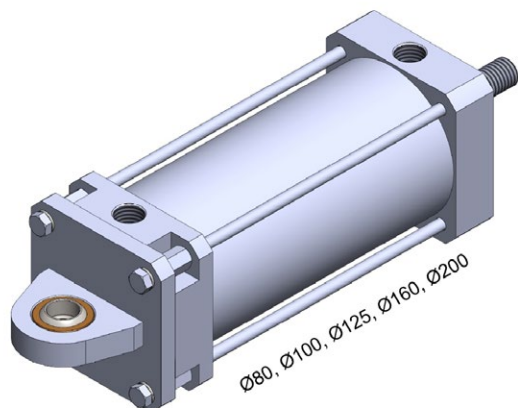



**KMB (ROD EYE MOUNTING) Ø80, Ø100, Ø125**

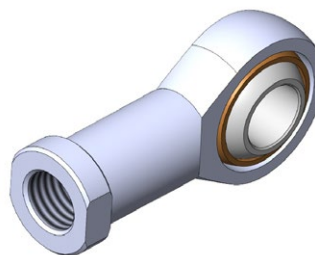
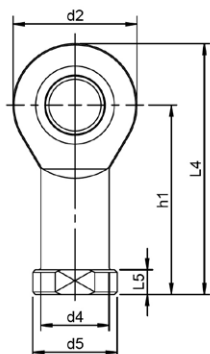
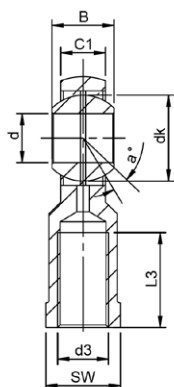

**KMB-K (ROD EYE MOUNTING) Ø160, Ø200, Ø250, Ø320, Ø400**

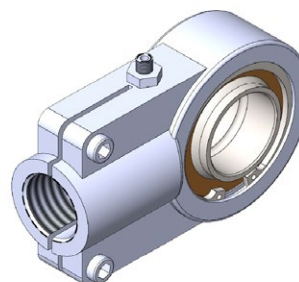
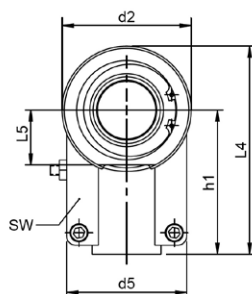
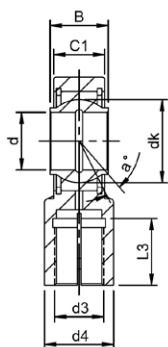

**ROD END NUT Ø80, Ø100, Ø125, Ø160, Ø200, Ø250, Ø320, Ø400**

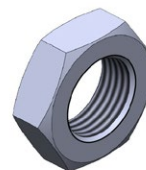
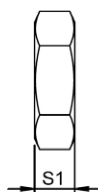
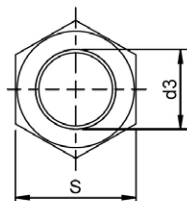

Cylinder Ø mm	Part Number	Dimensions (mm)															
		d	d3 6H	B	C1	W	L3 min	d2	L4	h1	L5	d4	d5	dk	a°	S	S1
80, 100	KMB-20	20	M20x1.5	25	18	30	33	50	102	77	10	27.5	34	34.925	14	30	10
125	KMB-25	25	M24x2.0	31	22	36	42	60	124	94	12	33.5	42	42.85	15	36	12
160, 200	KMB-K32	32	M27x2.0	32	28	22	37	71	118.5	80	32	38	66	44	4	41	13.5
250	KMB-K40	40	M33x2.0	40	33	26	46	90	146	97	41	47	80	53	4	50	16.5
320	KMB-K50	50	M42x2.0	50	41	32	57	109	179.5	120	50	58	96	66	4	65	16
400	KMB-K63	63	M48x2.0	63	53	38	64	136	213	140	62	70	114	83	4	75	18

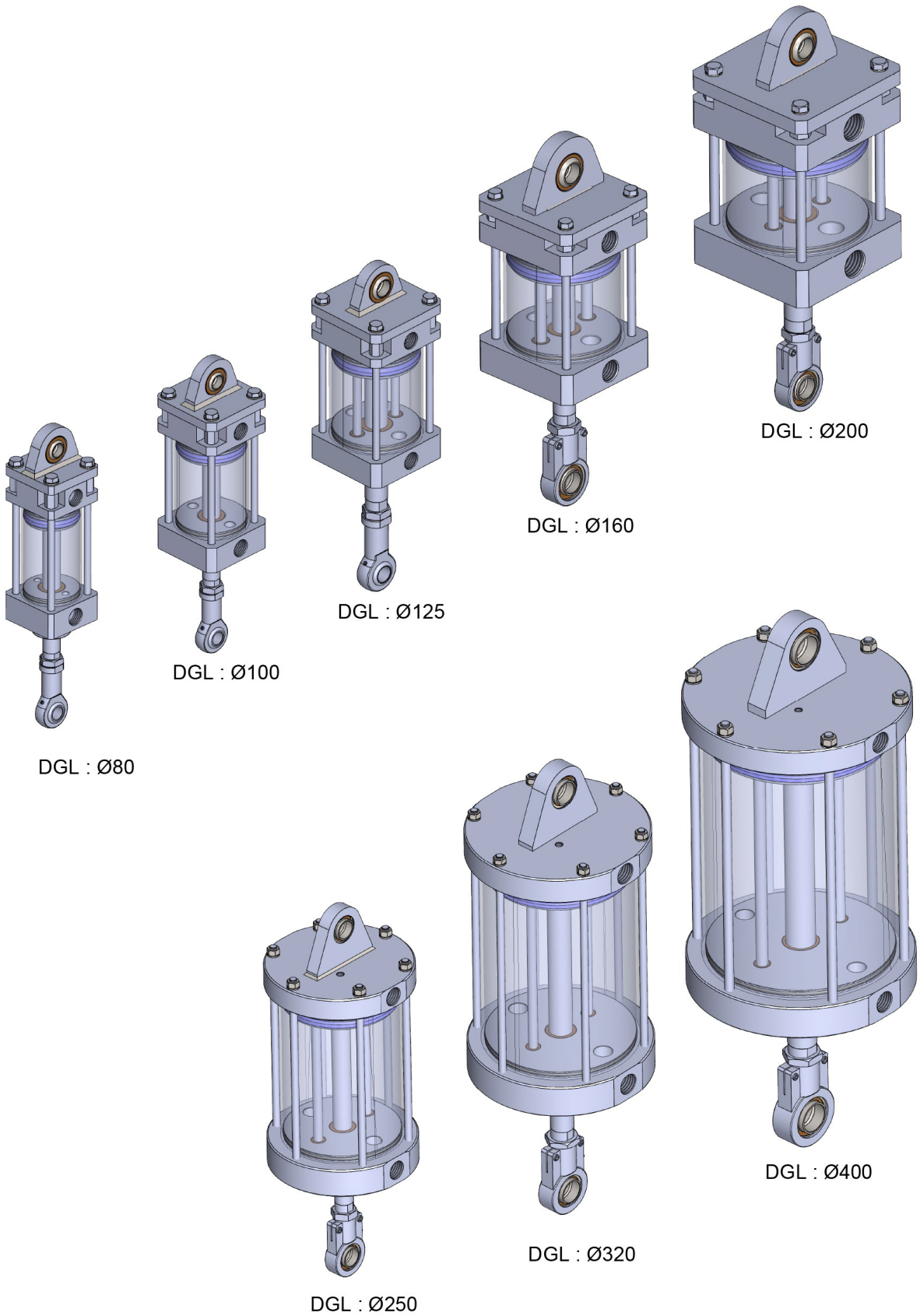

\*Please contact us for cylinder diameters over 400 mm.

## PEMAKS NOW ON SOCIAL MEDIA

FOLLOW OUR SOCIAL MEDIA ACCOUNTS FOR  
DEVELOPMENTS, NEW PRODUCTS AND SOLUTIONS.

